



# MASS-VIEW®

The intelligent alternative for VA meters:  
mass flow meters for gases with flow display



## › Introduction

Bronkhorst®, specialists in low flow measurement and control, have designed an innovative series of mass flow meters, regulators and controllers with integrated display. The MASS-VIEW® series provides modern, novel and economical alternative to variable area meters (VA meters), also known as purge meters. Unlike conventional VA meters these new flow meters measure mass flow instead of volume flow. For easy VA meter replacement the MASS-VIEW®'s mechanical construction offers the most common options for process connection on the market.

## › MASS-VIEW® series thermal mass flow meters

Bronkhorst designed MASS-VIEW® series operate on the principle of direct thermal mass flow measurement (no by-pass). An advantage of using this type of sensor is that the instrument measures direct mass flow, without the need of temperature and pressure correction. Other benefits, compared to conventional VA meters are higher accuracy, wider rangeability (up to 1:100), free of parallax errors and an inherently safer construction, by eliminating glass components in the flow path. MASS-VIEW® flow meters can be supplied in full scale ranges from 0,05 up to 500 l<sub>v</sub>/min (Air equivalent), with a pressure rating of 10 bar(g) or 150 psi(g). A bright graphical OLED display, clearly visible at wide angles, allows reading of actual flow (value and a bar graph), total flow and type of gas.

The display features easy set up via a user-friendly menu, using a 4-way navigation push button. The pre-installed gases eliminate the need to recalibrate for different gases and therefore reduce the cost of ownership. Additional features & functions include a variety of alarm and counter functions, an analog output signal, digital interfaces and two relay contacts. Flow control may be achieved with an optional needle valve. These high quality needle valves offer smooth and fine adjustment of the gas flow rates. The latest innovation to the MASS-VIEW® product line is the addition of an integrated auto-compensating controller. The desired flow rate is set via the needle valve in the usual way, however, any upstream pressure variation is now automatically compensated to ensure a steady, constant flow.

## › MASS-VIEW® features

- ◆ Clear indication in:
  - ◆ actual flow rate (bar graph and value)
  - ◆ desired flow units
  - ◆ type of gas
  - ◆ totalized flow
- ◆ Bright, wide-angle OLED display
- ◆ Free of parallax errors
- ◆ Virtually independent of pressure and temperature variations
- ◆ Low pressure drop
- ◆ Wide flow ranges
- ◆ Fast response
- ◆ High accuracy
- ◆ Electronic output, analog (0...5 Vdc) and digital interface

## › Digital features

- ◆ RS232 interface and Modbus ASCII/RTU communication
- ◆ Configurable password protection
- ◆ Alarm and counter functions
- ◆ Multi Gas / Multi Range
- ◆ Pre-installed gases
- ◆ Digitally calibrated
- ◆ Free Bronkhorst software tools



MASS-VIEW model MV-301 Mass Flow Regulator

## » Technical specifications

### Performance

Accuracy	± 2% RD for flow > 50% of max. capacity; ± (1% RD + 0,5% FS) on lower flows
Repeatability	< 0,2% FS typical < 0,6% FS typical for MV-108 / MV-308
Pre-installed gases	Air, Ar, N <sub>2</sub> , O <sub>2</sub> , CO <sub>2</sub> , CH <sub>4</sub> , C <sub>3</sub> H <sub>8</sub> , N <sub>2</sub> O, CO and C <sub>2</sub> H <sub>10</sub> Air, N <sub>2</sub> , O <sub>2</sub> , CO (models MV-101, MV-301 and MV-401) (special models available for H <sub>2</sub> and Helium)
Type of gases	Any clean and dry gas, filter recommended
Standard calibration gas	Air, other gases are converted using our Fluidat® conversion model which will introduce extra inaccuracy
Rangeability	up to 1:100
Operating pressure	0...10 bar(g) / 0...150 psi(g)
Pressure coefficient	± 0,2% RD/bar typical at Air
Operating temperature	0...50 °C (32...122 °F)
Temperature coefficient	Zero: <0,1% FS/°C, Span: <0,2% RD/°C
Attitude sensitivity	< 0,1% FS
Response time (t63%)	2 s

### Controller

min. Δp	1 bar(d) (for model MV-405 2 bar(d))
max. Δp	7 bar(d)
Control Accuracy	Less than 0,5-1% RD/bar

### Mechanical specifications

Materials (wetted parts)	Meter: aluminium, Viton® Needle valve: SS316, Viton®, PTFE; (for models MV-3x2 and MV-4xx: Fluorosint®, Brass, Buna N) Controller: membrane fiber-reinforced nitrile
Gas connections (in/out)	G 1/4" BSPP female thread G 1/2" BSPP female thread for MV-108 / MV-308 (compression fittings optional)
Weight	meter/regulator: 0,7 kg controller: 1,4 kg MV-108 / MV-308: 0,8 kg

### Electrical specifications

Electrical connection	8-pin RJ-45 modular jack
Output	analog: 0...5 Vdc digital: RS232 / RS485 (Modbus ASCII/RTU)
Required supply voltage	15...24 Vdc (+/-10%)
Power consumption	approx. 135 mA
Min. and max. relay contacts	switching current 0,5 A, 24 Vdc, one side grounded (0 Vdc power)

### Safety

Test pressure	21 bar(a) / 300 psi(a)
Ingress protection	IP40
EMC	EU declaration

### Warranty

All instruments and accessories are warranted for a period of 3 years from order date.

Technical specifications are subject to change without notice.

## » Model number identification

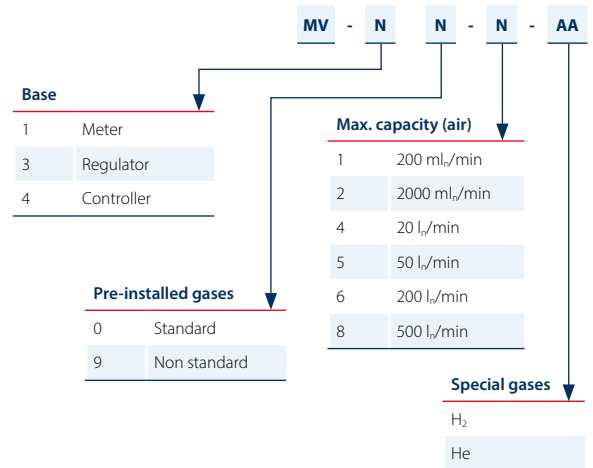

## » Dimensions

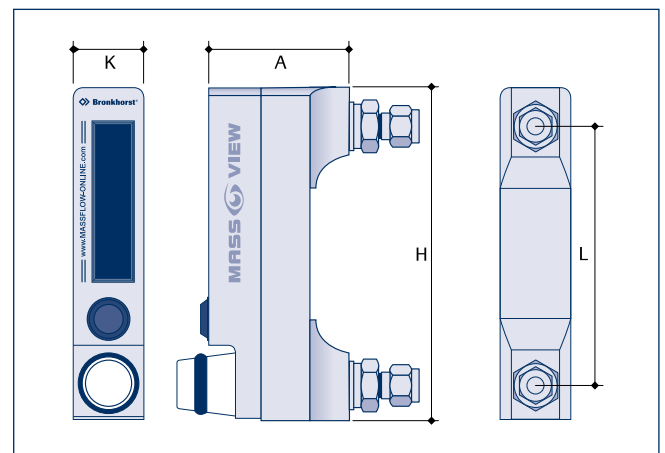

Model	A	H	K	L
MV-101/102/104/106/191/192/194/196	63	159	38	114
MV-108	75	159	38	114
MV-301/302/304/306/391/392/394/396	63	159	38	114
MV-308	75	159	38	114

Dimensions in mm.

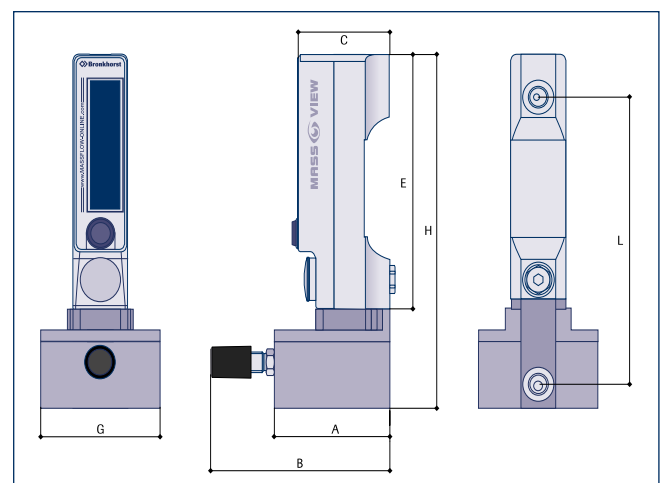

Model	A	B	C	E	G	H	L
MV-401/402/404/405	79	123	63	159	81,5	221	179

Dimensions in mm.

## Optional adapter sets (inlet and outlet)

Metric sizes	Inch sizes
3 mm OD compression type	1/8" OD compression type
6 mm OD compression type	1/4" OD compression type
12 mm OD compression type	1/2" OD compression type

## Electrical connection

Hook-up diagram

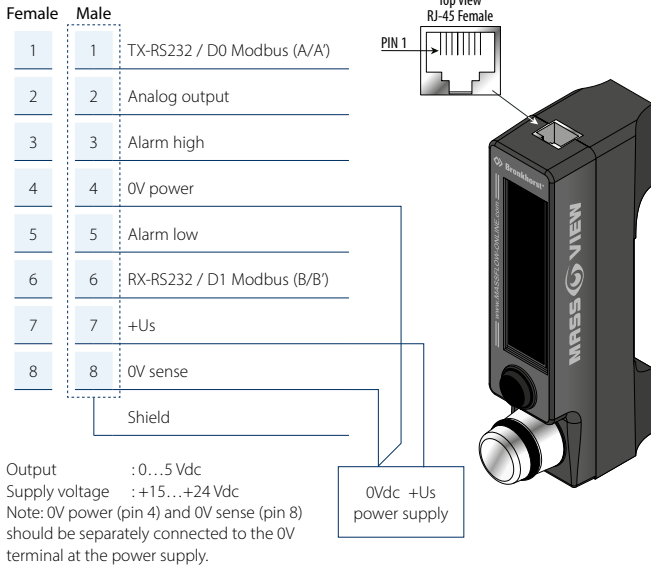

## Cabling options

Combinations for separate connection of power and I/O signals.

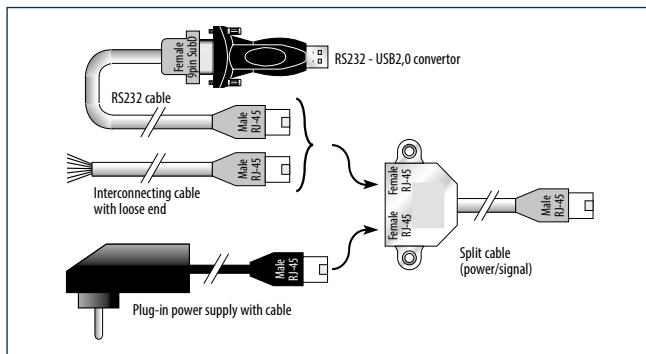

## Accessories

Following accessories are offered as an option for the MASS-VIEW® instruments.

### Power supply and electrical connection

	RJ-45 Multiport connector RS-485
	Split cable Power/Signal, 30 cm
	Plug-in Power Supply complete with cable 2 m. Universal input 100 to 240 Vac, output 15V/1,0A
	RS232 cable, RJ-45 - 9-pin Sub-D, 3 m
	RJ-45 Loose-end cable, 3 m, for power and signal connection by customer
	RS485 cable
	RS485 to USB2.0 connector
	RS232 to USB2.0 converter
	Terminator set
	Power isolator
	Battery pack for 24h of operation without power supply

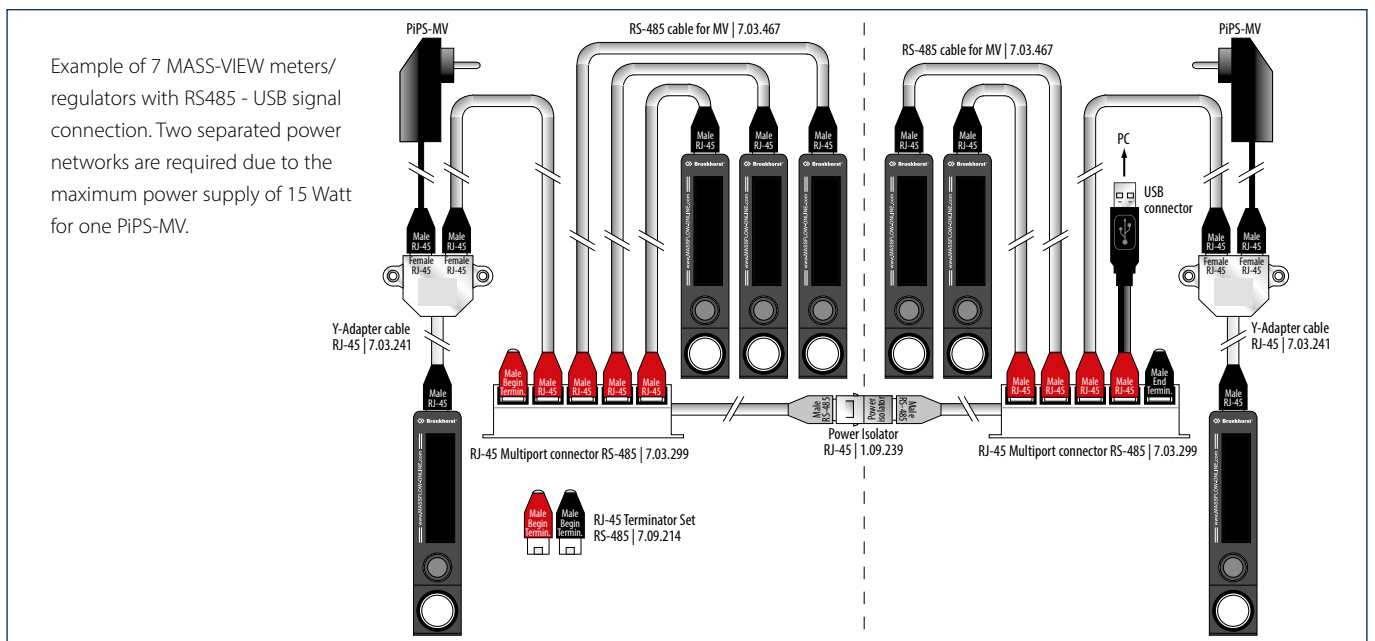

## Capacities

### CapacitiesSelectable ranges in l<sub>0</sub>/min (SLM)

	Air	N <sub>2</sub>	O <sub>2</sub>	CO	Ar	CO <sub>2</sub>	CH <sub>4</sub>	N <sub>2</sub> O	C <sub>2</sub> H <sub>6</sub>	C <sub>4</sub> H <sub>10</sub>
<b>MV-101, MV-301</b>										
Range 1 (max.)	0,01...0,2	0,01...0,2	0,01...0,2	0,01...0,2	-	-	-	-	-	-
Range 2	0,01...0,1	0,01...0,1	0,01...0,1	0,01...0,1	-	-	-	-	-	-
Range 3 (min.)	0,01...0,05	0,01...0,05	0,01...0,05	0,01...0,05	-	-	-	-	-	-
<b>MV-102, MV-302</b>										
Range 1 (max.)	0,02...2	0,02...2	0,02...2	0,02...2	0,04...4	0,02...2	0,01...1	0,02...2	0,02...1	0,01...1
Range 2	0,02...1	0,02...1	0,02...1	0,02...1	0,04...2	0,02...1	0,01...0,5	0,02...1	0,02...0,5	0,01...0,5
Range 3	0,02...0,5	0,02...0,5	0,02...0,5	0,02...0,5	0,04...1	0,02...0,5	0,01...0,2	0,02...0,5	0,02...0,2	0,01...0,2
Range 4 (min.)	0,02...0,2	0,02...0,2	0,02...0,2	0,02...0,2	0,04...0,5	0,02...0,2	0,01...0,1	0,02...0,2	0,02...0,1	0,01...0,1
<b>MV-104, MV-304</b>										
Range 1 (max.)	0,2...20	0,2...20	0,2...20	0,2...20	0,4...40	0,2...20	0,1...10	0,2...20	0,1...10	0,1...10
Range 2	0,1...10	0,1...10	0,1...10	0,1...10	0,2...20	0,1...10	0,05...5	0,1...10	0,05...5	0,05...5
Range 3	0,05...5	0,05...5	0,05...5	0,05...5	0,1...10	0,05...5	0,02...2	0,05...5	0,02...2	0,02...2
Range 4 (min.)	0,04...2	0,04...2	0,04...2	0,04...2	0,08...5	0,04...2	0,02...1	0,04...2	0,02...1	0,02...1
<b>MV-106, MV-306</b>										
Range 1 (max.)	2...200	2...200	2...200	2...200	4...400	2...200	1...100	2...200	1...100	1...100
Range 2	1...100	1...100	1...100	1...100	2...200	1...100	0,5...50	1...100	0,5...50	0,5...50
Range 3	0,5...50	0,5...50	0,5...50	0,5...50	1...100	0,5...50	0,2...20	0,5...50	0,2...20	0,2...20
Range 4 (min.)	0,4...20	0,4...20	0,4...20	0,4...20	0,8...50	0,4...20	0,2...10	0,4...20	0,2...10	0,2...10
<b>MV-108, MV-308</b>										
Range 1 (max.)	5...500	5...500	5...500	5...500	10...1000	5...500	2,5...250	5...500	2,5...250	2,5...250
Range 2	2...200	2...200	2...200	2...200	5...500	2...200	1,25...125	2...200	1,25...125	1,25...125
Range 3	1...100	1...100	1...100	1...100	2...200	1...100	0,625...62,5	1...100	0,625...62,5	0,625...62,5
Range 4 (min.)	1...50	1...50	1...50	1...50	2...100	1...50	0,5...25	1...50	0,5...25	0,5...25
<b>MV-401</b>										
Range 1 (max.)	0,02...0,2	0,02...0,2	0,02...0,2	0,02...0,2	-	-	-	-	-	-
Range 2	0,02...0,1	0,02...0,1	0,02...0,1	0,02...0,1	-	-	-	-	-	-
Range 3 (min.)	0,02...0,05	0,02...0,05	0,02...0,05	0,02...0,05	-	-	-	-	-	-
<b>MV-402</b>										
Range 1 (max.)	0,02...2	0,02...2	0,02...2	0,02...2	0,04...4	0,02...2	0,01...1	0,01...1	0,02...2	0,01...1
Range 2	0,02...1	0,02...1	0,02...1	0,02...1	0,04...2	0,02...1	0,01...0,5	0,01...0,5	0,02...1	0,01...0,5
Range 3	0,02...0,5	0,02...0,5	0,02...0,5	0,02...0,5	0,04...1	0,02...0,5	0,01...0,2	0,01...0,2	0,02...0,5	0,01...0,2
Range 4 (min.)	0,02...0,2	0,02...0,2	0,02...0,2	0,02...0,2	0,04...0,5	0,02...0,2	0,01...0,1	0,01...0,1	0,02...0,2	0,01...0,1
<b>MV-404</b>										
Range 1 (max.)	0,2...20	0,2...20	0,2...20	0,2...20	0,4...20	0,2...20	0,1...10	0,1...10	0,2...20	0,1...10
Range 2	0,1...10	0,1...10	0,1...10	0,1...10	0,2...20	0,1...10	0,01...0,5	0,05...5	0,1...10	0,05...5
Range 3	0,05...5	0,05...5	0,05...5	0,05...5	0,1...10	0,05...5	0,01...0,2	0,02...2	0,05...5	0,02...2
Range 4 (min.)	0,04...2	0,04...2	0,04...2	0,04...2	0,08...5	0,04...2	0,01...0,1	0,02...1	0,04...2	0,02...1
<b>MV-405</b>										
Range 1 (max.)	0,5...50	0,5...50	0,5...50	0,5...50	-	-	-	-	-	-
Range 2	0,2...20	0,2...20	0,2...20	0,2...20	-	-	-	-	-	-
Range 3	0,1...10	0,1...10	0,1...10	0,1...10	-	-	-	-	-	-
Range 4 (min.)	0,05...5	0,05...5	0,05...5	0,05...5	-	-	-	-	-	-

## » Capacities for H<sub>2</sub> and He

Selectable ranges in I <sub>0</sub> /min (SLM)	H <sub>2</sub>
<b>MV-191-H2, MV-391-H2</b>	
Range 1 (max.)	0,02...0,2
Range 2	0,02...0,1
Range 3	0,02...0,05
<b>MV-192-H2, MV-392-H2</b>	
Range 1 (max.)	0,05...1
Range 2	0,05...0,5
Range 3	0,05...0,2
Range 4 (min.)	0,05...0,1
<b>MV-194-H2, MV-394-H2</b>	
Range 1 (max.)	0,1...10
Range 2	0,1...5
Range 3	0,1...2
Range 4 (min.)	0,1...1
<b>MV-196-H2, MV-396-H2</b>	
Range 1 (max.)	1...100
Range 2	0,5...50
Range 3	0,2...20
Range 4 (min.)	0,2...10

Selectable ranges in I <sub>0</sub> /min (SLM)	He
<b>MV-191-HE, MV-391-HE</b>	
Range 1 (max.)	0,02...0,2
Range 2	0,02...0,1
Range 3	0,02...0,05
<b>MV-192-HE, MV-392-HE</b>	
Range 1 (max.)	0,05...2
Range 2	0,05...1
Range 3	0,05...0,5
Range 4 (min.)	0,05...0,2
<b>MV-194-HE, MV-394-HE</b>	
Range 1 (max.)	0,2...20
Range 2	0,1...10
Range 3	0,1...5
Range 4 (min.)	0,1...2
<b>MV-196-HE, MV-396-HE</b>	
Range 1 (max.)	1...100
Range 2	0,5...50
Range 3	0,2...20
Range 4 (min.)	0,2...10

## ➤ Applications

- ◆ The fields of application for MASS-VIEW® are diverse:
- ◆ Burner control (furnace construction)
- ◆ Welding (welding gas monitoring)
- ◆ Leak measurements (quality, environment)
- ◆ Coating (equipment construction)
- ◆ Regulation of gaseous atmospheres (biotechnology)
- ◆ Measurement of gas consumption (hospitals)
- ◆ Test equipment (production maintenance)
- ◆ Local preparation of a gas mixture
- ◆ Flow rate monitoring (laboratories)
- ◆ Cutting (steel sheets)
- ◆ Cost centre billing
- ◆ Analytical equipment
- ◆ Aeration / sparging (food products, ice cream / edible oils)
- ◆ Blanketing (food)
- ◆ Fermentation (food, biotechnology, pharma)



## ➤ Display menu

The 4-way navigation push button provides access to a user-friendly menu, e.g. for zero function, for selection of pre-installed gases in pre-installed capacities, setting of engineering units, alarm functions (minimum/maximum/counter limit) and counter functions. Password protection is provided to prevent unauthorized changes. Below overview of the MASS-VIEW® menu functions illustrates the great versatility of this product line.

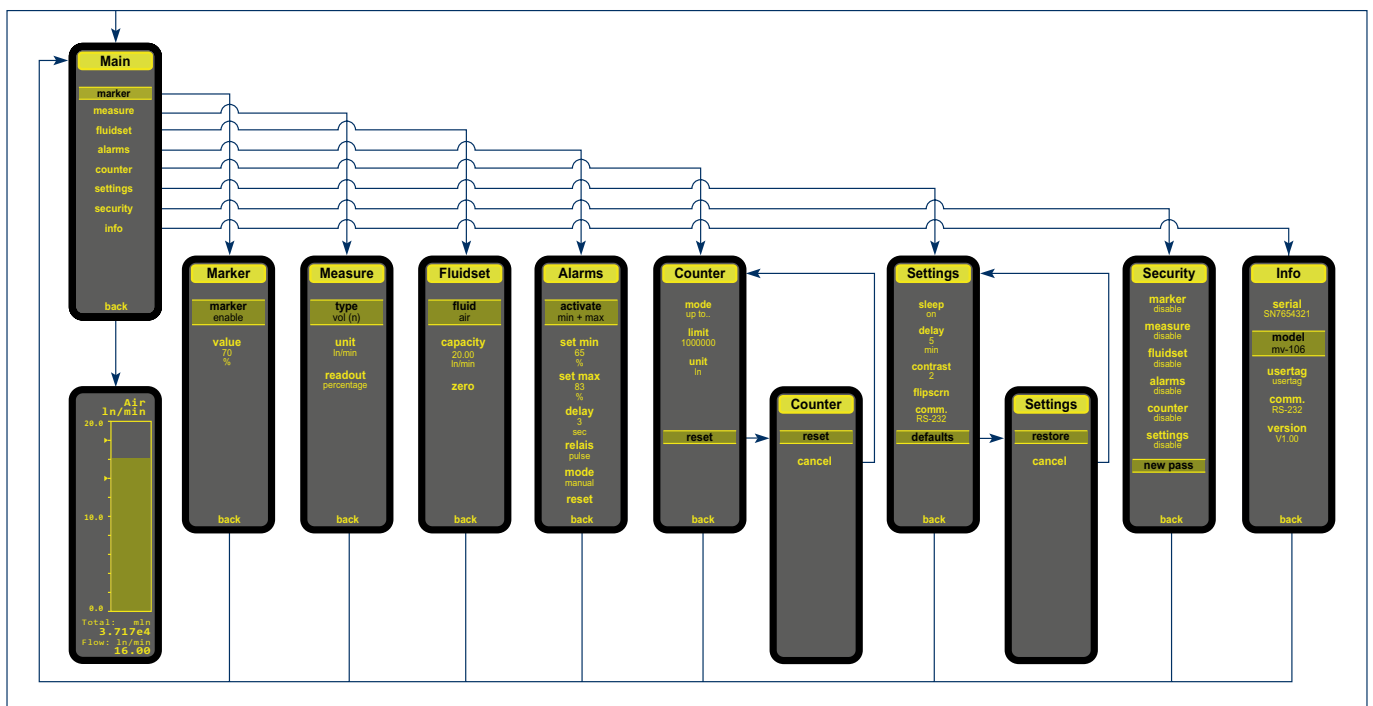

## ➤ Bronkhorst® FlowWare, free software tools

Bronkhorst offers following software support for installation and operation by personal computer:

- ◆ FlowDDE: Software tool to interface between digital instruments and MS Windows software.
- ◆ FlowPlot: Software tool for monitoring and optimizing digital instruments parameters.

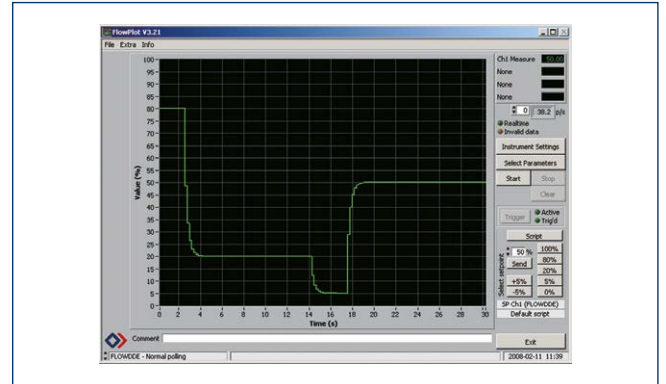

- ◆ FlowView: Software tool to interface between digital instruments.

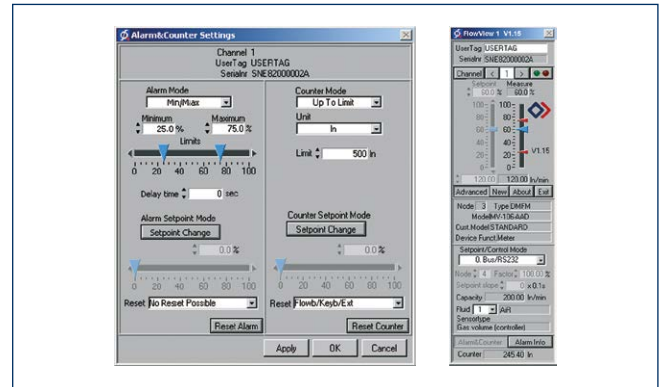

These software tools are freeware for users of our MASS-VIEW® series and other digital Bronkhorst instruments and can be downloaded from [www.massflow-online.com](http://www.massflow-online.com)



[www.massflow-online.com](http://www.massflow-online.com)

The products in this brochure can be ordered easily from stock at Mass Flow ONLINE B.V., 24 hours a day, 7 days a week on [www.massflow-online.com](http://www.massflow-online.com). From this web shop, we deliver competitively priced, high quality products with excellent delivery time. Your on-line order will be shipped within two working days.

9.60.0181 L2201406 ©Bronkhorst\*