

OPERATING MANUAL

PM[B]sense

PM / CO₂ transmitter



EN
V1.5



Contents

1	Introduction	3
2	Technical specifications.....	4
3	Installation.....	5
	3.1 Electrical connections	5
4	Configuration and measurement	8
5	ASCII proprietary protocol	9
6	Modbus-RTU protocol	18
7	Maintenance	23
8	Safety instructions	23
9	Accessories ordering codes	24

1 Introduction

PMsense is a **PM1.0**, **PM2.5** and **PM10** Particulate Matter transmitter suitable for outdoor air quality monitoring.

The dust particles concentration is measured using the laser scattering principle.

An optional CO₂ sensor can be integrated in the transmitter (**PMBsense**).

The transmitter has a digital RS485 output with Modbus-RTU or ASCII proprietary protocol. A version with two additional 0/4...20 mA (0...10 V **on request when ordering**) analog outputs is available. The two analog outputs can be independently associated with any of the measured parameters.

The measuring circuit of the transmitter can be operated in continuous mode or, in order to extend the PM sensor lifetime, at cyclic intervals (default operating mode). The measuring cycle interval is user configurable.

The transmitter is maintenance-free and has fast response, high sensitivity, excellent stability and long operating life.

Models

Model	Measurement		Output	
	PM	CO ₂	RS485	Analog
PMsense-M	√		√	
PMsense-A	√		√	0/4...20 mA
PMsense-V	√		√	0...10 V
PMBsense-M	√	√	√	
PMBsense-A	√	√	√	0/4...20 mA
PMBsense-V	√	√	√	0...10 V

2 Technical specifications

Particulate Matter	
Measuring principle	Laser scattering
Measured pollutants	PM1.0, PM2.5 and PM10
Measuring range	0...1000 µg/m ³ (for each pollutant)
Particle size detection range	∅ 0.3...10 µm
Linearity error	< 5%
Repeatability	< 3%
Sensor warm up time	15 s
Sensor lifetime	5 years approx. in 5 minutes cyclic operating mode (default) > 10,000 hours in continuous operating mode (1 meas./s)
Temperature drift	< 0.01 µg/m ³ /°C
CO₂ (only PMBsense...)	
Measuring principle	Double wavelength NDIR
Measuring range	0...5000 ppm
Accuracy	±(50 ppm+3% of measurement) @ 25 °C and 1013 hPa
Response time	< 120 s (air speed= 2 m/s)
Long-term stability	5% of measurement / 5 years
Temperature drift	1 ppm/°C
General specifications	
Output	RS485 with Modbus-RTU or ASCII proprietary protocol 2 x analog 0/4...20 mA (R _{Lmax} = 500 Ω) – Only P[B]Msense-A 2 x analog 0...10 V (R _{Lmin} = 10 kΩ) - Only P[B]Msense-V
Power supply	7...30 Vdc (15...30 Vdc for 0...10 V analog outputs)
Power consumption	25 mA @ 24 Vdc during measurement 4 mA in stand-by (only for cyclic operating mode) The indicated consumption does not include the consumption due to the analog outputs
Connection	M12 8-pole circular connector
Operating conditions	-20...+70 °C / 0...95 %RH / 500...1500 hPa
Housing material	Polycarbonate
Protection degree	Housing equipped with a rain-proof and UV resistant inlet air filter – IP 53
Dimensions	120 x 94 x 71 (excluding M12 connector)
Weight	330 g

3 Installation

The transmitter is equipped with a bracket with U-bolt for the fixing to a Ø40...50 mm mast. It can be fixed to a wall using the bracket only, by removing the U-bolt.

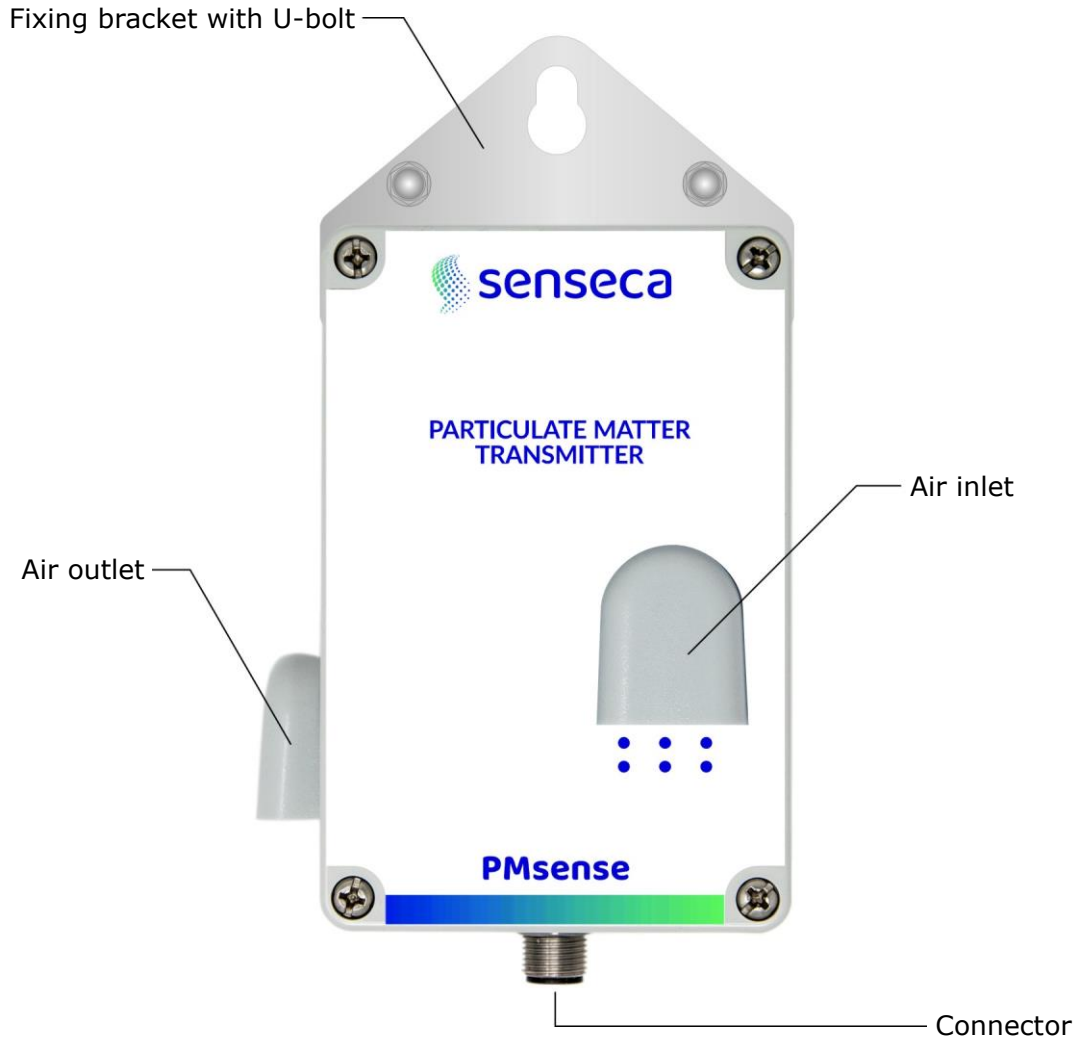

Fig. 3.1: transmitter description

3.1 Electrical connections

The transmitter has a M12 8-pole circular connector and uses the **CPM12-8PM... optional** cables, with M12 8-pole connector on one side and open wires on the other side.

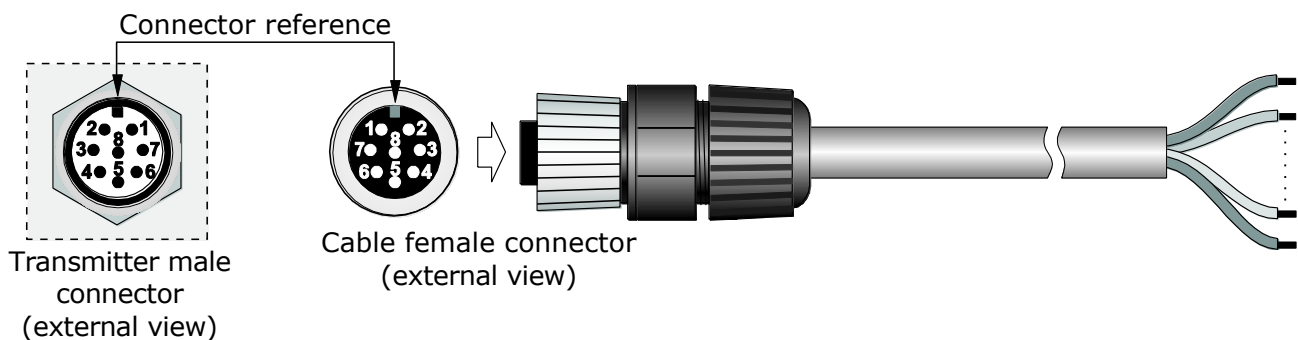

Fig. 3.2: connectors pinout

Connector pin N°	Function	CPM12-8PM... wire color
1	GND (Power supply negative)	Blue
2	+Vdc (Power supply positive)	Red
3	Not used	---
4	DATA - (RS485)	Brown
5	DATA + (RS485)	White
6	SGND (Digital and analog outputs ground)*	Grey
7	AOUT1 (Analog output 1 positive)	Yellow
8	AOUT2 (Analog output 2 positive)	Green
	Cable shield **	Black (thick wire)

* The output ground (SGND) and the negative of the power supply (GND) are short-circuited inside the transmitter.

* The cable shield is not connected to the M12 connector.

To ensure a good noise immunity, it is recommended to connect the cable shield to ground (GND).

RS485 output and analog outputs connections:

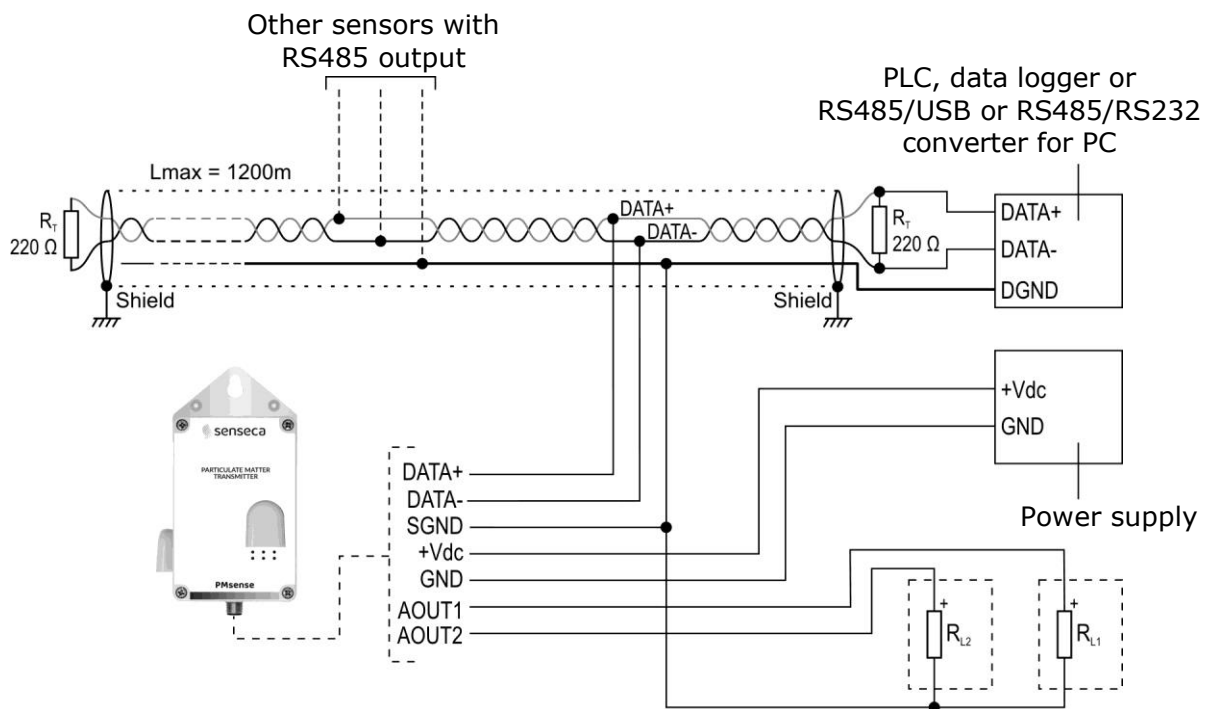

Fig. 3.3: connections

RS485 output:

The RS485 output is not isolated. Before connecting the sensor to the RS485 network, set the address and the communication parameters, if different from the factory preset (see "Configuration" chapter).

Current analog output (only PM[B]sense-A):

By default, the current analog outputs are 4...20 mA, with:

$$4 \text{ mA} = 0 \text{ } \mu\text{g}/\text{m}^3$$

$$20 \text{ mA} = 1000 \text{ } \mu\text{g}/\text{m}^3$$

The analog output 1 is associated by default to PM2.5. The analog output 2 is associated by default to PM10.

With the commands of the proprietary protocol it is possible to associate the analog outputs to different parameters, set the range 0...20 mA for the output and reverse the direction of the output, so that the output decreases as the measurement increases.

In case of measurement error, the output goes to 22 mA.

Voltage analog output (only PM[B]sense-V):

By default, the voltage analog outputs are 0...10 V, with:

$$0 \text{ V} = 0 \text{ } \mu\text{g}/\text{m}^3$$

$$10 \text{ V} = 1000 \text{ } \mu\text{g}/\text{m}^3$$

The analog output 1 is associated by default to PM2.5. The analog output 2 is associated by default to PM10.

With the commands of the proprietary protocol it is possible to associate the analog outputs to different parameters, set the range 2...10 V for the output and reverse the direction of the output, so that the output decreases as the measurement increases.

In case of measurement error, the output goes to 11 V.

4 Configuration and measurement

The configuration of the instrument and the reading of the measurements can be done via the RS485 serial output, both with the proprietary protocol and with the Modbus-RTU protocol.

In the first 10 seconds after the instrument power on, it is always active the proprietary protocol. After 10 seconds from power on, the operating protocol is activated, which by default is the Modbus-RTU protocol.

It is possible to keep the proprietary protocol active even after 10 seconds from power on by sending, before the 10 seconds expire, the command @ of the proprietary protocol. The proprietary protocol can be set as operating protocol by means of the DPO command.

The commands of the proprietary protocol and the registers of the Modbus-RTU protocol are described in detail in the following chapters.

Particulate Matter measurement modes:

The transmitter can perform the PM measurement in continuous mode or, in order to extend the sensor lifetime, at cyclic intervals (default).

In the measurement mode at cyclic intervals, the PM sensor is activated periodically for the ON time. The measurement is made available after 70 seconds from sensor activation (warm-up time). At the end of the ON time, the measurement is "frozen" and the sensor is deactivated until the set cyclic measurement interval expires.

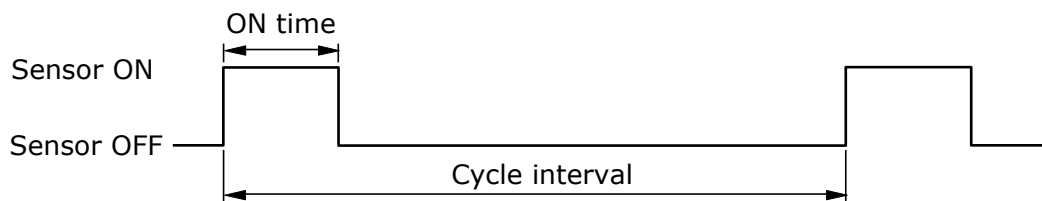

Fig. 4.1: Measurement mode at cyclic intervals

The measurement mode, the cycle interval and the sensor ON time can be configured respectively by using the CPLS, CPLP and CPLO commands of the proprietary protocol or the holding registers with address 15, 16 and 18 of the Modbus-RTU protocol.

The transmitter provides three types of measurements:

- average over a 10 seconds interval, updated every second;
- average over a 60 seconds interval, updated every 10 seconds;
- average over a 15 min interval, updated every minute.

For the measurement mode at cyclic intervals, the cycle interval and the ON time must be set consistently with the desired averaging interval.

Status of the transmitter:

There are two LEDs on the internal electronic board of the transmitter: the **green** LED indicates the presence of the external power supply (blinks once per second), the **red** LED indicates the presence of any measurement errors (normally off, it blinks twice per second if at least one of the measured parameters is in error).

5 ASCII proprietary protocol

To use the proprietary protocol, it is necessary to connect the instrument to the PC via a RS485/USB (e.g. RS51K) or RS485/RS232 converter and use a standard serial communication program. In the serial communication program, set the COM port number to which the instrument is connected and the communication parameters as follows:

- If the Modbus-RTU protocol is set as the operating protocol in the instrument (default), set the Baud Rate 57600 and the parameters 8N2 in the serial communication program, then power cycle the instrument and send the command @ within 10 seconds from the instrument power on.
- If the proprietary protocol is already set as the operating protocol in the instrument, it is possible to operate with Baud Rate 57600 and parameters 8N2 by sending the command @ within 10 seconds from the instrument power on, or you can let the 10 seconds pass without sending the command @ and operate with the communication parameters set in the instrument (default 19200, 8E1).

To change the instrument configuration, the serial command **CAL USER ON** must be sent first (the instrument replies with USER CAL MODE ON). The command CAL USER ON is automatically disabled after a few minutes of inactivity. If the settings should be only read, the command CAL USER ON is not required.

Below is the list of the serial commands.

Instrument information

Command	Reply	Description
G0	<i>Model</i>	Instrument model
G1	<i>&Revision </i>	Instrument hardware revision
G2	SN=nnnnnnnn	Instrument serial number
G3	Firm.Ver.=x.y	Instrument firmware revision
G4	Firm.Date=yyyy/mm/dd	Date of firmware revision
GC	Fact.Calib.Date= yyyy/mm/dd User.Calib.Date= yyyy/mm/dd Cal.Mode= <i>Factory</i> or <i>User</i>	Date of factory calibration Date of user calibration Type of calibration active

Protocol

Command	Reply	Description
@	&	Keeps the proprietary protocol operational even after 10 seconds from instrument power on. It must be sent within 10 seconds from instrument power on.
DPn	&	Sets the operating protocol: <ul style="list-style-type: none"> ▪ Proprietary if n=0 ▪ Modbus-RTU if n=1 <i>Default</i> : Modbus-RTU (n=1)
GP	& n	Reads the operating protocol set in the instrument.
SM	&	Activates the Modbus-RTU protocol immediately.
CMA n	&	Sets the instrument address for the MODBUS-RTU protocol to n. The address should range within 1 and 247. <i>Default</i> : 1
RMA	& n	Reads the instrument address for the Modbus-RTU protocol.

Note: after sending the DP1 command, the instrument remains with the proprietary protocol. Send the command SM to activate the Modbus-RTU protocol immediately, or power cycle the instrument.

RS485 communication parameters

Command	Reply	Description
CMBn	&	Sets the Baud Rate: <ul style="list-style-type: none"> ▪ 1200 if n=0 ▪ 2400 if n=1 ▪ 4800 if n=2 ▪ 9600 if n=3 ▪ 19200 if n=4 ▪ 38400 if n=5 ▪ 57600 if n=6 ▪ 115200 if n=7 <i>Default</i> : 19200 (n=4)
RMB	& n	Reads Baud Rate setting
CMPn	&	Sets parity and stop bits: <ul style="list-style-type: none"> ▪ 8N1 if n=0 [No parity, 1 stop bit] ▪ 8N2 if n=1 [No parity, 2 stop bits] ▪ 8E1 if n=2 [Even parity, 1 stop bit] ▪ 8E2 if n=3 [Even parity, 2 stop bits] ▪ 8O1 if n=4 [Odd parity, 1 stop bit] ▪ 8O2 if n=5 [Odd parity, 2 stop bits] The number of data bits is fixed to 8. <i>Default</i> : 8E1 (n=2)
RMP	& n	Reads the setting of parity and stop bits.
CMWn	&	Sets waiting time after transmission with Modbus-RTU protocol: <ul style="list-style-type: none"> ▪ Immediate reception if n=0 (violates protocol) ▪ Waiting 3.5 characters if n=1 (respects protocol) <i>Default</i> : Immediate reception (n=0)
RMW	& n	Reads the setting of waiting time after transmission with Modbus-RTU protocol.

PM measurement settings

Command	Reply	Description
CPLSn	&	Sets the PM measurement mode: <ul style="list-style-type: none"> ▪ Continuous if n=0 ▪ At cyclic intervals if n=1 <i>Default</i> : At cyclic intervals (n=1)
RPLS	& n	Reads the setting of the PM measurement mode.
CPLPn	&	Sets the cycle interval for the measurement mode at cyclic intervals. <i>Default</i> : 300 (=5 min)
RPLP	& n	Reads the setting of the cycle interval for the measurement mode at cyclic intervals.
CPLOn	&	Sets the sensor ON time for the measurement mode at cyclic intervals to n seconds. It must be greater than 70 s (warm-up time). <i>Default</i> : 71
RPLO	& n	Reads the setting of the sensor ON time for the measurement mode at cyclic intervals.

Reading of the measurement information

Command	Reply	Description
CPSn	&	Sets the type of PM measurement averaging for the analog outputs and the measurements sent by the transmitter in reply to P1, P5, S1 and S5 commands or when reading Modbus Input Registers 0...5: <ul style="list-style-type: none"> ▪ Average over a 10 seconds interval, updated every second if n=0 ▪ Average over a 60 seconds interval, updated every 10 seconds if n=1 ▪ Average over a 15 minutes interval, updated every minute if n=2 <i>Default : Average over a 10 seconds interval, updated every second (n=0)</i>
RPS	& n	Reads the type of averaging for the measurements sent by the transmitter in reply to P1, P5, S1 and S5 commands.
P0	&	Disable the sending of the measurement enabled with P1.
P1	&	Enable the sending of the PM measurement every second (the sequence is the same described in command P5).
P5	& <i>Measurements</i>	Prints the PM measurements in the following sequence: <ul style="list-style-type: none"> ▪ PM measurement error (0=no, 1=yes) ▪ PM1.0 in N° of particles/ml ▪ PM2.5 in N° of particles/ml ▪ PM10 in N° of particles/ml ▪ PM1.0 in µg/m³ ▪ PM2.5 in µg/m³ ▪ PM10 in µg/m³ <i>The PM measurement is averaged according to what is set with CPS command or Modbus holding register 19.</i>
S0	&	Disable the sending of the measurement enabled with S1.
S1	&	Enable the sending of the measurement every second (the sequence is the same described in command S5).
S5	& <i>Measurements</i>	Prints the measurements in the following sequence: <ul style="list-style-type: none"> ▪ PM measurement error (0=no, 1=yes) ▪ PM1.0 in µg/m³ ▪ PM2.5 in µg/m³ ▪ PM10 in µg/m³ ▪ CO₂ in ppm ▪ Atmospheric pressure in hPa (internal sensor for CO₂ measurement compensation) ▪ <i>Field not used</i> ▪ <i>Field not used</i> ▪ <i>Field not used</i> ▪ Power supply voltage ▪ Internal board temperature <i>The PM measurement is averaged according to what is set with CPS command or Modbus holding register 19.</i>

Analog outputs (only PM[B]sense-A)

Command	Reply	Description
CA1On	&	Enable/disable the offset of the analog output 1: <ul style="list-style-type: none"> ▪ Offset disabled if n=0 (0...20 mA or 0...10 V) ▪ Offset enabled if n=1 (4...20 mA or 2...10 V) <i>Default</i> : Offset enabled (n=1) if the output is current, offset disabled (n=0) if the output is voltage
RA1O	& n	Reads the setting of the offset for the analog output 1.
CA1SO	&	Sets the direct or inverse correspondence between analog output 1 and associated physical quantity: <ul style="list-style-type: none"> ▪ 4 mA/0 V ⇒ Min. quantity, 20 mA/10 V ⇒ Max. quantity if n=0 ▪ 20 mA/10 V ⇒ Min. quantity, 4 mA/0 V ⇒ Max. quantity if n=1 <i>Default</i> : Direct correspondence (n=0)
RA1SO	& n	Reads the type of correspondence (direct or inverse) between analog output 1 and associated physical quantity.
CA1Tn	&	Associates the analog output 1 to: <ul style="list-style-type: none"> ▪ PM1.0 if n=0 ▪ PM2.5 if n=1 ▪ PM10 if n=2 ▪ CO₂ if n=12 (only PMBsense-A) <i>Default</i> : PM2.5 (n=1) <i>The PM measurement is averaged according to what is set with CPS command or Modbus holding register 19.</i>
RA1T	& n	Reads the physical quantity associated to analog output 1.
CA1Ln	&	Sets n as the minimum value of the measuring range of the physical quantity associated to the analog output 1. If the output is associated to PM, the value must be expressed as a number of tenths (e.g. n=5 to indicate 0.5 µg/m ³). If the output is associated to CO ₂ , the value must be expressed as a number of units (e.g. n=200 to indicate 200 ppm). <i>Default</i> : 0
RA1L	& n	Reads the minimum value of the measuring range of the physical quantity associated to the analog output 1.
CA1Hn	&	Sets n as the maximum value of the measuring range of the physical quantity associated to the analog output 1. If the output is associated to PM, the value must be expressed as a number of tenths (e.g. n=50 to indicate 5.0 µg/m ³). If the output is associated to CO ₂ , the value must be expressed as a number of units (e.g. n=800 to indicate 800 ppm). <i>Default</i> : 10000 (=1000.0 µg/m ³ of PM)
RA1H	& n	Reads the maximum value of the measuring range of the physical quantity associated to the analog output 1.
RA1F	& <i>Quantity</i> <i>Minimum value</i> <i>Maximum value</i>	Simultaneously provides the information obtainable with the RA1T, RA1L e RA1H commands.

Command	Reply	Description
CA2On	&	Enable/disable the offset of the analog output 2: <ul style="list-style-type: none"> ▪ Offset disabled if n=0 (0...20 mA or 0...10 V) ▪ Offset enabled if n=1 (4...20 mA or 2...10 V) <i>Default</i> : Offset enabled (n=1) if the output is current, offset disabled (n=0) if the output is voltage
RA2O	& n	Reads the setting of the offset for the analog output 2.
CA2SO _n	&	Sets the direct or inverse correspondence between analog output 2 and associated physical quantity: <ul style="list-style-type: none"> ▪ 4 mA/0 V ⇒ Min. quantity, 20 mA/10 V ⇒ Max. quantity if n=0 ▪ 20 mA/10 V ⇒ Min. quantity, 4 mA/0 V ⇒ Max. quantity if n=1 <i>Default</i> : Direct correspondence (n=0)
RA2SO	& n	Reads the type of correspondence (direct or inverse) between analog output 2 and associated physical quantity.
CA2T _n	&	Associates the analog output 2 to: <ul style="list-style-type: none"> ▪ PM1.0 if n=0 ▪ PM2.5 if n=1 ▪ PM10 if n=2 ▪ CO₂ if n=12 (only PMBsense-A) <i>Default</i> : PM10 (n=2) <i>The PM measurement is averaged according to what is set with CPS command or Modbus holding register 19.</i>
RA2T	& n	Reads the physical quantity associated to analog output 2.
CA2L _n	&	Sets n as the minimum value of the measuring range of the physical quantity associated to the analog output 2. If the output is associated to PM, the value must be expressed as a number of tenths (e.g. n=5 to indicate 0.5 µg/m ³). If the output is associated to CO ₂ , the value must be expressed as a number of units (e.g. n=200 to indicate 200 ppm). <i>Default</i> : 0
RA2L	& n	Reads the minimum value of the measuring range of the physical quantity associated to the analog output 2.
CA2H _n	&	Sets n as the maximum value of the measuring range of the physical quantity associated to the analog output 2. If the output is associated to PM, the value must be expressed as a number of tenths (e.g. n=50 to indicate 5.0 µg/m ³). If the output is associated to CO ₂ , the value must be expressed as a number of units (e.g. n=800 to indicate 800 ppm). <i>Default</i> : 10000 (=1000 µg/m ³ of PM)
RA2H	& n	Reads the maximum value of the measuring range of the physical quantity associated to the analog output 2.
RA2F	& <i>Quantity</i> <i>Minimum value</i> <i>Maximum value</i>	Simultaneously provides the information obtainable with the RA2T, RA2L e RA2H commands.

Calibration

Calibration of PM measurement in µg/m³ (not in N° of particles/ml) and CO₂ measurement (only PMBsense...) can be performed.

PM1.0, PM2.5 and PM10 calibrations are independent.

A 2-point calibration (CPMx1/CPMx2 commands for PM, CO21/CO22 commands for CO₂), to adjust both the offset and the slope of the sensor response curve, or a 1-point calibration (CPMxO commands for PM, CO2O command for CO₂), to simply add an offset to the measurement, can be performed. The calibration points are chosen by the user.

PM calibration with commands CPMx1, CPMx2 and CPMxO is applied to the measurement averaged according to what is set with CPS command or Modbus holding register 19.

For PM measurement only, it is also possible to manually configure the calibration in 2 points (CPMxM... commands), without having to place the transmitter in an environment of known PM concentration. This option is useful if it is available the sensor characterization, i.e., the correspondence between the transmitter measurement and the measurement of a reference instrument in a series of points. The option also allows the sensor response curve to be adjusted to minimize the mean square error (in this case, the values to be entered must be derived by the user by applying a linear regression method to the sensor characterization).

Before performing PM or CO₂ calibration, the CAL USER ON command must be sent and the type of calibration to be used must be set to "user" (CC1 command).

The transmitter allows manually setting, with the DA command, a string that is saved as the date and time of the calibration. The string must be set before performing the calibration.

Command	Reply	Description
Type of calibration		
CCn	&	Sets the type of calibration to be used: <ul style="list-style-type: none"> ▪ Factory if n=0 ▪ User if n=1 The setting applies to both PM and CO ₂ . <i>Default</i> : Factory (n=0)
Date of calibration		
DAyyyy/mm/dd hh:mm:ss	&	Saves the string "aaaa/mm/gg hh:mm:ss" as the date and time when calibration is performed. The command must be sent before performing the calibration.
GA	& yyyy/mm/dd hh:mm:ss	Reads the date and time saved with the DA command.

Command	Reply	Description
PM1.0 calibration		
CPM11n	&	2-point PM1.0 calibration: calibrates first point at n, expressed as a number of tenths of µg/m ³ (e.g. n=5 indicates 0.5 µg/m ³). The transmitter must first be placed in an environment with a known PM1.0 concentration (the value n entered in the command).
CPM12n	&	2-point PM1.0 calibration: calibrates second point at n, expressed as a number of tenths of µg/m ³ . Operation similar to the CPM11 command.
CPM10n	&	1-point PM1.0 calibration (offset adjustment) at n, expressed as a number of tenths of µg/m ³ . Operation similar to the CPM11 command.
CPM1Mx ₀ y ₀ x ₁ y ₁	&	Manual configuration of PM1.0 calibration in 2 points. A mapping is performed so that the 2 reference values x ₀ and x ₁ correspond to y ₀ and y ₁ measurements provided by the transmitter, respectively (x ₀ → y ₀ , x ₁ → y ₁). x ₀ , y ₀ , x ₁ , y ₁ are expressed as a number of tenths of µg/m ³ . Example: CPM1M0 10 10000 9985 performs the mapping 0.0 µg/m ³ → 1.0 µg/m ³ and 1000.0 µg/m ³ → 998.5 µg/m ³ .
ZPM1	& x ₀ y ₀ x ₁ y ₁	Reads the current PM1.0 calibration mapping.
CPM1D	&	Reset of PM1.0 user calibration.
PM2.5 calibration		
CPM21n	&	2-point PM2.5 calibration: calibrates first point at n, expressed as a number of tenths of µg/m ³ (e.g. n=5 indicates 0.5 µg/m ³). The transmitter must first be placed in an environment with a known PM2.5 concentration (the value n entered in the command).
CPM22n	&	2-point PM2.5 calibration: calibrates second point at n, expressed as a number of tenths of µg/m ³ . Operation similar to the CPM21 command.
CPM20n	&	1-point PM2.5 calibration (offset adjustment) at n, expressed as a number of tenths of µg/m ³ . Operation similar to the CPM21 command.
CPM2Mx ₀ y ₀ x ₁ y ₁	&	Manual configuration of PM2.5 calibration in 2 points. A mapping is performed so that the 2 reference values x ₀ and x ₁ correspond to y ₀ and y ₁ measurements provided by the transmitter, respectively (x ₀ → y ₀ , x ₁ → y ₁). x ₀ , y ₀ , x ₁ , y ₁ are expressed as a number of tenths of µg/m ³ . Example: CPM2M0 10 10000 9985 performs the mapping 0.0 µg/m ³ → 1.0 µg/m ³ and 1000.0 µg/m ³ → 998.5 µg/m ³ .
ZPM2	& x ₀ y ₀ x ₁ y ₁	Reads the current PM2.5 calibration mapping.
CPM2D	&	Reset of PM2.5 user calibration.

Command	Reply	Description
PM10 calibration		
CPM31n	&	2-point PM10 calibration: calibrates first point at n, expressed as a number of tenths of µg/m ³ (e.g. n=5 indicates 0.5 µg/m ³). The transmitter must first be placed in an environment with a known PM10 concentration (the value n entered in the command).
CPM32n	&	2-point PM10 calibration: calibrates second point at n, expressed as a number of tenths of µg/m ³ . Operation similar to the CPM31 command.
CPM30n	&	1-point PM10 calibration (offset adjustment) at n, expressed as a number of tenths of µg/m ³ . Operation similar to the CPM31 command.
CPM3Mx ₀ y ₀ x ₁ y ₁	&	Manual configuration of PM10 calibration in 2 points. A mapping is performed so that the 2 reference values x ₀ and x ₁ correspond to y ₀ and y ₁ measurements provided by the transmitter, respectively (x ₀ → y ₀ , x ₁ → y ₁). x ₀ , y ₀ , x ₁ , y ₁ are expressed as a number of tenths of µg/m ³ . Example: CPM3M0 10 10000 9985 performs the mapping 0.0 µg/m ³ → 1.0 µg/m ³ and 1000.0 µg/m ³ → 998.5 µg/m ³ .
ZPM3	& x ₀ y ₀ x ₁ y ₁	Reads the current PM10 calibration mapping.
CPM3D	&	Reset of PM10 user calibration.
PM calibration total reset		
CPMD	&	Reset of PM1.0, PM2.5 and PM10 user calibration.
CO₂ calibration		
CO21n	& t	2-point CO ₂ calibration: calibrates first point at n ppm. The transmitter must first be placed in an environment with a known CO ₂ concentration (the value n entered in the command). The value t in the reply to the command indicates the number of seconds required for the transmitter to complete the calibration operation. During this time, the transmitter sends strings notifying the progress of the operation; for example: "CO2 calib. Status:IN PROGRESS 8% Avg:1096ppm Dev:0ppm" At the end, the OK 100% notification indicates that the operation was successful; for example: "CO2 calib. Status:OK 100% Avg:1100ppm Dev:7ppm"
CO22n	& t	2-point CO ₂ calibration: calibrates second point at n ppm. Operation similar to the CO21command.
CO20n	& t	1-point CO ₂ calibration (offset adjustment) at n ppm. Operation similar to the CO21 command.
CO2D	&	Reset of CO ₂ user calibration.

Restoring the factory configuration

Command	Reply	Description
DFLT	&	Restores the factory configuration.

6 Modbus-RTU protocol

By default, the instrument has Modbus address **1** and communication parameters 19200, 8E1. The address and the communication parameters can be changed by using the appropriate serial commands of the proprietary protocol or, alternatively, directly with Modbus commands by changing the value of the Coils and Holding Registers described later.

The Modbus-RTU protocol, if set as the operating protocol (default), is active after 10 seconds from the instrument power on.

In order to change the instrument configuration using the Modbus-RTU protocol, the value 1 must be written first in the *Coil* with address 1.

Below is the list of registers.

Input Registers:

Address	Description	Format
0	PM1.0 in N° of particles/ml. <i>Measurement averaged according to what is set with CPS command or Modbus holding register 19.</i>	16-bit Integer
1	PM2.5 in N° of particles/ml. <i>Measurement averaged according to what is set with CPS command or Modbus holding register 19.</i>	16-bit Integer
2	PM10 in N° of particles/ml. <i>Measurement averaged according to what is set with CPS command or Modbus holding register 19.</i>	16-bit Integer
3	PM1.0 in µg/m ³ (x10). <i>Measurement averaged according to what is set with CPS command or Modbus holding register 19.</i>	16-bit Integer
4	PM2.5 in µg/m ³ (x10). <i>Measurement averaged according to what is set with CPS command or Modbus holding register 19.</i>	16-bit Integer
5	PM10 in µg/m ³ (x10). <i>Measurement averaged according to what is set with CPS command or Modbus holding register 19.</i>	16-bit Integer
6	PM1.0 in N° of particles/ml. <i>Measurement averaged over 10 s and updated every second.</i>	16-bit Integer
7	PM2.5 in N° of particles/ml. <i>Measurement averaged over 10 s and updated every second.</i>	16-bit Integer
8	PM10 in N° of particles/ml. <i>Measurement averaged over 10 s and updated every second.</i>	16-bit Integer
9	PM1.0 in µg/m ³ (x10). <i>Measurement averaged over 10 s and updated every second.</i>	16-bit Integer
10	PM2.5 in µg/m ³ (x10). <i>Measurement averaged over 10 s and updated every second.</i>	16-bit Integer

Address	Description	Format
11	PM10 in µg/m ³ (x10). <i>Measurement averaged over 10 s and updated every second.</i>	16-bit Integer
12	PM1.0 in N° of particles/ml. <i>Measurement averaged over 60 s and updated every 10 s.</i>	16-bit Integer
13	PM2.5 in N° of particles/ml. <i>Measurement averaged over 60 s and updated every 10 s.</i>	16-bit Integer
14	PM10 in N° of particles/ml. <i>Measurement averaged over 60 s and updated every 10 s.</i>	16-bit Integer
15	PM1.0 in µg/m ³ (x10). <i>Measurement averaged over 60 s and updated every 10 s.</i>	16-bit Integer
16	PM2.5 in µg/m ³ (x10). <i>Measurement averaged over 60 s and updated every 10 s.</i>	16-bit Integer
17	PM10 in µg/m ³ (x10). <i>Measurement averaged over 60 s and updated every 10 s.</i>	16-bit Integer
18	PM1.0 in N° of particles/ml. <i>Measurement averaged over 15 min and updated every minute.</i>	16-bit Integer
19	PM2.5 in N° of particles/ml. <i>Measurement averaged over 15 min and updated every minute.</i>	16-bit Integer
20	PM10 in N° of particles/ml. <i>Measurement averaged over 15 min and updated every minute.</i>	16-bit Integer
21	PM1.0 in µg/m ³ (x10). <i>Measurement averaged over 15 min and updated every minute.</i>	16-bit Integer
22	PM2.5 in µg/m ³ (x10). <i>Measurement averaged over 15 min and updated every minute.</i>	16-bit Integer
23	PM10 in µg/m ³ (x10). <i>Measurement averaged over 15 min and updated every minute.</i>	16-bit Integer
26	PM measurement error: 0=no, 1=yes.	Inter 16 bit
28	CO ₂ in ppm.	Inter 16 bit
33 + 34	Atmospheric pressure in Pa (*) <i>Internal sensor for CO₂ measurement compensation</i>	Inter 32 bit
35	Atmospheric pressure in hPa (x10) <i>Internal sensor for CO₂ measurement compensation</i>	Inter 16 bit
37	Power supply voltage in Volt (x10).	16-bit Integer
38	Internal board temperature (x10).	16-bit Integer
40	Instrument firmware revision. The most significant byte indicates the major revision; the less significant byte indicates the minor revision.	16-bit Integer
41	Number of Modbus communication error.	16-bit Integer

(*) The measure is a 32-bit integer value. Two consecutive registers (33 and 34) must be ac-

cessed to read the value. The register with lower address contains the least significant bits.

Coils:

Address	Description	Format
0	Set 1 to restore the factory configuration. Bit zeroing is automatic.	Bit
1	Enable configuration change: 0=no (default), 1=yes. The changes to <i>Coils</i> and <i>Holding Registers</i> will be accepted only if this register is set to 1.	Bit
2	Sets waiting time after transmission with Modbus-RTU protocol: 0=immediate reception (default); 1=waiting 3.5 characters.	Bit
3	Enable/disable the offset of the analog output 1: 0=offset disabled (0...20 mA or 0...10 V, default if the output is voltage); 1=offset enabled (4...20 mA or 2...10 V, default if the output is current).	Bit
4	Sets the direct or inverse correspondence between analog output 1 and associated physical quantity: 0=4 mA/0 V ⇒ Min. quantity, 20 mA/10 V ⇒ Max. quantity (default); 1=20 mA/10 V ⇒ Min. quantity, 4 mA/0 V ⇒ Max. quantity.	Bit
5	Enable/disable the offset of the analog output 2: 0=offset disabled (0...20 mA or 0...10 V, default if the output is voltage); 1=offset enabled (4...20 mA or 2...10 V, default if the output is current).	Bit
6	Sets the direct or inverse correspondence between analog output 2 and associated physical quantity: 0=4 mA/0 V ⇒ Min. quantity, 20 mA/10 V ⇒ Max. quantity (default); 1=20 mA/10 V ⇒ Min. quantity, 4 mA/0 V ⇒ Max. quantity.	Bit

Holding Registers:

Address	Description	Format
0	RS485 Baud Rate: 0=1200; 1=2400; 2=4800; 3=9600; 4=19200 (default); 5=38400; 6=57600; 7=115200.	16-bit Integer
1	RS485 parity and stop bits: 0=8N1; 1=8N2; 2=8E1 (default); 3=8E2; 4=8O1; 5=8O2. [N=no parity, E=even parity, O=odd parity]	16-bit Integer
2	Instrument address for the Modbus-RTU protocol (1...247, default=1).	16-bit Integer
3	Association of a physical quantity to the analog output 1: 0=PM1.0; 1=PM2.5 (default); 2=PM10; 12=CO ₂ (only PMBsense-A). <i>The PM measurement is averaged according to what is set with CPS command or Modbus holding register 19.</i>	16-bit Integer
6 + 7	Setting of the minimum value of the measuring range of the physical quantity associated to the analog output 1. (*) If the output is associated to PM, the value is expressed as a number of tenths (e.g. 5 = 0.5 µg/m ³). If the output is associated to CO ₂ , the value is expressed as a number of units (e.g. 200 = 200 ppm). The default value is 0.	32-bit Integer
8 + 9	Setting of the maximum value of the measuring range of the physical quantity associated to the analog output 1. (*) If the output is associated to PM, the value is expressed as a number of tenths (e.g. 50 = 5.0 µg/m ³). If the output is associated to CO ₂ , the value is expressed as a number of units (e.g. 800 = 800 ppm). The default value is 10000 (=1000.0 µg/m ³ of PM).	32-bit Integer
10	Association of a physical quantity to the analog output 2: 0=PM1.0; 1=PM2.5; 2=PM10 (default); 12=CO ₂ (only PMBsense-A). <i>The PM measurement is averaged according to what is set with CPS command or Modbus holding register 19.</i>	16-bit Integer

Address	Description	Format
11 + 12	Setting of the minimum value of the measuring range of the physical quantity associated to the analog output 2. (*) If the output is associated to PM, the value is expressed as a number of tenths (e.g. 5 = 0.5 µg/m ³). If the output is associated to CO ₂ , the value is expressed as a number of units (e.g. 200 = 200 ppm). The default value is 0.	32-bit Integer
13 + 14	Setting of the maximum value of the measuring range of the physical quantity associated to the analog output 2. (*) If the output is associated to PM, the value is expressed as a number of tenths (e.g. 50 = 5.0 µg/m ³). If the output is associated to CO ₂ , the value is expressed as a number of units (e.g. 800 = 800 ppm). The default value is 10000 (=1000.0 µg/m ³ of PM).	32-bit Integer
15	Setting of the PM measurement mode: 0=continuous; 1=at cyclic intervals (default).	16-bit Integer
16	Setting of the cycle interval, in seconds, for the PM measurement mode at cyclic intervals. The default value is 300 (=5 min).	16-bit Integer Unsigned
18	Setting of the sensor ON time, in seconds, for the PM measurement mode at cyclic intervals. It must be greater than 70 s (warm-up time). The default value is 71.	16-bit Unsigned Integer
19	Setting of the type of PM measurement averaging for the analog outputs and the measurements sent by the transmitter in reply to P1, P5, S1 and S5 commands (proprietary protocol) or when reading Modbus Input Registers 0...5: 0=average over a 10 seconds interval, updated every second; 1=average over a 60 seconds interval, updated every 10 seconds (default); 2=average over a 15 minutes interval, updated every minute.	16-bit Integer
20	Setting of the type of CO ₂ calibration to be used: 0=user; 1=factory (default).	16-bit Integer

For 32-bit values, two consecutive registers must be accessed (e.g. 6 and 7 for the setting of the minimum value of the measuring range of the physical quantity associated to the analog output 1). The register with lower address contains the least significant bits.

7 Maintenance

Periodically check the cleanliness of the air inlet and outlet grids.

Do not use aggressive cleaning agents or incompatible with the materials indicated in the technical specifications. For cleaning, use a soft dry cloth or slightly dampened with clean water.

8 Safety instructions

The instrument proper operation and operating safety can be ensured only in the climatic conditions specified in this manual and if all standard safety measures as well as the specific measures described in this manual are followed.

Do not use the instruments in places where there are:

- Corrosive or flammable gases.
- Direct vibrations or shocks to the instrument.
- High-intensity electromagnetic fields, static electricity.

User obligations

The instrument operator shall follow the directives and regulations below that refer to the treatment of dangerous materials:

- EU directives on workplace safety.
- National law regulations on workplace safety.
- Accident prevention regulations.

9 Accessories ordering codes

- CPM12-8PM.x** Cable with 8-pole M12 connector on one end, open wires on the other end. Length 5 m (CPM12-8PM.5) or 10 m (CPM12-8PM.10).
- RS51K** Kit for connecting the transmitter RS485 output to a PC. It includes the SWD10 power supply and the RS485/USB adapter with:
- screw terminals for the connection to the CPM12-8PM.x cable (not included);
 - USB connector for the connection to the PC;
 - jack connector for connecting the SWD10 power supply.

NOTES

NOTES

WARRANTY

The manufacturer is required to respond to the "factory warranty" only in those cases provided by Legislative Decree 6 September 2005 - n. 206. Each instrument is sold after rigorous inspections; if any manufacturing defect is found, it is necessary to contact the distributor where the instrument was purchased from. During the warranty period (24 months from the date of invoice) any manufacturing defects found will be repaired free of charge. Misuse, wear, neglect, lack or inefficient maintenance as well as theft and damage during transport are excluded. Warranty does not apply if changes, tampering or unauthorized repairs are made on the product. Solutions, probes, electrodes and microphones are not guaranteed as the improper use, even for a few minutes, may cause irreparable damages.

The manufacturer repairs the products that show defects of construction in accordance with the terms and conditions of warranty included in the manual of the product. For any dispute, the competent court is the Court of Padua. The Italian law and the "Convention on Contracts for the International Sales of Goods" apply.

TECHNICAL INFORMATION

The quality level of our instruments is the result of the continuous product development. This may lead to differences between the information reported in the manual and the instrument you have purchased.

We reserve the right to change technical specifications and dimensions to fit the product requirements without prior notice.

DISPOSAL INFORMATION

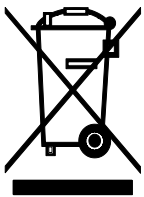

Electrical and electronic equipment marked with specific symbol in compliance with 2012/19/EU Directive must be disposed of separately from household waste. European users can hand them over to the dealer or to the manufacturer when purchasing a new electrical and electronic equipment, or to a WEEE collection point designated by local authorities. Illegal disposal is punished by law.

Disposing of electrical and electronic equipment separately from normal waste helps to preserve natural resources and allows materials to be recycled in an environmentally friendly way without risks to human health.



senseca.com



Senseca Italy S.r.l.
Via Marconi, 5
35030 Selvazzano Dentro (PD)
ITALY
info@senseca.com

